

# Continuous level measurement in liquids

## Achieving the perfect fit for your application



# Contents

About this guide.....	<b>Page 3</b>
1. Level measurement using radar.....	<b>Page 4</b>
1.1 Level measurement overview.....	<b>Page 5</b>
1.2 Application limits.....	<b>Page 7</b>
1.3 Radar selection aid.....	<b>Page 8</b>
2. Guided wave radar.....	<b>Page 9</b>
2.1 Level measurement using guided wave radar.....	<b>Page 10</b>
2.2 Levelflex gas phase compensation.....	<b>Page 12</b>
3. Capacitive level measurement.....	<b>Page 13</b>
4. Hydrostatic.....	<b>Page 17</b>
5. General selection.....	<b>Page 21</b>

# About this guide

Level transmitters are used to measure the level in tanks, channels and basins and the range of measurement technologies available can seem bewildering when tasked with choosing a device for a specific application.

It remains as true today as ever before that no single technology is the ideal choice for every level measurement task when all selection criteria, including cost, are taken into account.

Level measurement has been a rapidly changing area of instrumentation with newer technologies replacing more maintenance-intensive technologies. Developments particularly in the field of radar level measurement have broadened the appeal of a technology that was previously seen as difficult and expensive.

This short guide is intended as an introduction to the main technologies used today for measuring level in process applications. As such we will concentrate mainly here on radar, guided wave radar, hydrostatics and capacitance as these technologies offer solutions to the majority of level measurement tasks. Other technologies may offer advantages in some more extreme applications.



# 1. Level measurement using radar

Radar level measurement has become the first choice non-contact measurement technology to solve level measurement challenges in a variety of different applications.

The key to achieving the ideal solution is choosing the right device for the right application. This primarily comes down to selecting the right operating frequency and antenna design. Process level radars are available operating at three frequencies: 6 GHz, 26 GHz and 80 GHz. There is an extensive range of antenna designs available, ranging from traditional metallic cones to plastic rod antennas and innovative designs to combat issues with condensation. As with frequency it is also the case that each design has its own unique benefits and no single design is the best fit for all applications.

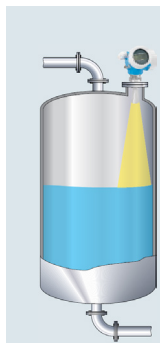

## ✓ Advantages

- Non-contact, maintenance-free measurement
- Unaffected by medium properties like density and conductivity
- For high temperatures up to +450°C

Radar level measurement is based on the Time-of-Flight principle and the measurement works by emitting high-frequency electromagnetic waves either continuously or pulsed. This is emitted by an antenna and reflected from the product surface. A measurement of the distance from the radar to the liquid surface is calculated. The Time-of-Flight of the reflected radar pulse or wave is directly proportional to the distance travelled. If the tank geometry is known, the level can be calculated from this variable.

Radar level transmitters infer the level by measuring the distance from a fixed mounting point to the surface of the liquid to be measured. To make this distance measurement, two technologies exist. Process radars can be split into two types: pulse and frequency modulated continuous wave (FMCW).

[▶ Click here to watch our video on the Time-of-Flight principle >>>](#)



# 1.1 Level measurement overview

- Radar devices measure the distance (D) between antenna and product surface by emitting microwaves.
- Propagation speed of microwaves is the speed of light  $c$  (300,000,000m/s).
- The result of pulse as well as FMCW radars is the measurement of distance (D).
- The tank height or empty distance (E) is typically known.
- With (E), the level (L) can easily be calculated:

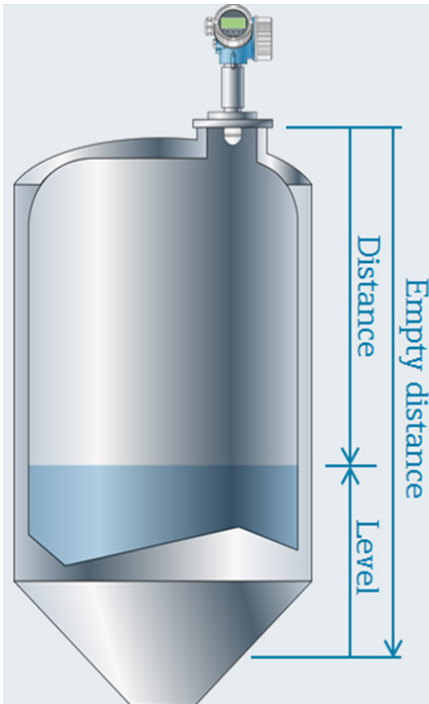

## FMCW radar

- Distance measurement by comparing the frequency of emitted and received signal.
- Calculating distance (D) based on frequency difference ( $\Delta f$ )
- Indirect method

$$D = \frac{c \cdot T_M \cdot \Delta f}{2 \cdot (f_{\max} - f_{\min})}$$

Pulse radar was the main method of radar level measurement due to its relative simplicity to implement when compared to FMCW. In the past the complexity of the signal evaluation meant that an FMCW radar required far greater processing power and hence supply power. This made making a 2-wire process FMCW level radar with the required accuracy and reaction times extremely difficult.

## Pulse radar

- Distance measurement based on the Time-of-Flight (t) between emitting and receiving the reflected radar signal
- Direct method

$$D = \frac{c \cdot t}{2}$$

With modern electronics this is no longer the case and FMCW 2-wire radar transmitters are now available in the marketplace. FMCW is particularly suited to 80 GHz radar and this is where it is generally to be found, whilst pulse measurement still dominates at the lower frequencies.

The first process radars used for level measurement had an operating frequency of 6 GHz. Since then additional higher operating frequencies to match specific application needs have been added to the range available. It is often perceived that because the latest radar has a higher operating frequency than its predecessors that higher is always better. This is incorrect and there are many applications where for example a 6 GHz radar would be preferred over a new 80 GHz radar. Three measurement frequencies of 6 GHz, 26 GHz and 80 GHz are generally used for level measurement.

**6 GHz** Typically the antenna of a 6 GHz radar will be large when compared with higher frequency devices and this may limit their suitability in some applications. The spread of the emitted microwave energy (beam angle) will also be much wider than a higher frequency radar with a similar sized antenna. This large beam angle and long wavelength can both be an advantage in some applications and a disadvantage in others. It may be difficult to mount the transmitter in a suitable location avoiding reflections from internal fittings in the vessel. 6 GHz radars are the least affected by turbulent surfaces and they can be used with boiling surfaces that may prove problematic with higher frequency devices.

[▶ Watch our video on 6GHz radar instruments >>>](#)

**26 GHz** This has become the most popular frequency for process level radars and offers a good mix of attributes to suit the majority of process level measurement tasks. Whilst the microwave energy is more easily attenuated

than a 6 GHz radar, it will easily cope with thin light foams which may occur during vessel filling operations. With the higher operating frequency the antenna can be much smaller making them more suitable for tall vessels or avoiding obstructions in a vessel that may give false echoes. Modern antenna designs based on PTFE lenses rather than traditional metallic antennae remove the problems associated with condensation.

[▶ Watch our video on 26GHz radar instruments >>>](#)

**80 GHz** Beam angles with 80 GHz transmitters can be incredibly small making them ideal for very tall vessels or vessels where multiple obstructions must be avoided. Due to the short wavelength it is also possible to make smaller process connections allowing the use of radar on  $\frac{3}{4}$ " connections. Modern antenna designs based on PTFE lenses rather than traditional metallic antennae remove the problems associated with condensation and are standard on 80 GHz devices.

[▶ Watch our video on 80GHz radar instruments >>>](#)

**Mounting** The ideal situation for a radar level measurement would be a perfectly flat calm liquid surface with the radar mounted absolutely perpendicular. Under such circumstances the echo returned to the transmitter is maximised. In real world process applications the liquid surface can range from this ideal situation to extremely turbulent or even boiling surfaces where a 6 GHz radar will perform best.

For calm surfaces the most important aspect

is that the radar is mounted perpendicular to the surface, as a minimum does not deviate by more than half of the beam angle. This is easy to achieve with 6 GHz and 26 GHz devices but attention must be paid when installing 80 GHz radars. With beam angles as low as  $3^\circ$  the alignment must be better than  $1.5^\circ$ .



## 1.2 Application limits

The amplitude of the received echo from the liquid surface is of importance in evaluating the signal and can be adversely affected by a number of influences.

Foam presents a particular challenge for radar level measurement. In most normal applications where thin, light foam may exist then any frequency can be expected to perform without issue. As a general rule 6 GHz radars offer the best possibility of seeing the liquid level below the foam and 80 GHz radars offer the best possibility of receiving an echo from the top of the foam. However, in both cases there are some definite limitations.

The first thing to consider is the nature of the foam that might be present – is it a light non-conductive foam or a dense water-based foam? For light foam made up of large bubbles, a 6 GHz radar may penetrate well and give a useable echo up to 50cm or so of foam. The limiting factor becomes the thickness of the foam as the attenuation of the microwave energy increases the thicker or denser the foam becomes. For thicker foams made up of small bubbles it may be possible to get a reflection from the surface of the foam, particularly when using 80 GHz devices.

The main problem that arises is that foams are often not consistent and the thickness and density will vary with changing process conditions. In this case it is possible that the level signal will jump between the surface of the foam and the true liquid level.

In some circumstances the microwave energy may be entirely absorbed by the foam and no usable echo is returned to the transmitter resulting in a loss of level control.

As foam reduces the amplitude of the received echo then it is possible to use a radar to give a warning that foam is present so that countermeasures such as the addition of an antifoam agent can be applied to the process. Endress+Hauser has applied this as an option on its process radars. A fuller explanation is given in the video link below.

 [Watch our video on Heartbeat Monitoring for foam detection >>>](#)



# 1.3 Radar selection aid

	6 GHz		26 GHz				80 GHz		
	FMR53	FMR54	FMR10/20	FMR50	FMR51	FMR52	FMR60	FMR62	
Condensation / build-up						PTFE antenna with drip-off function	Drip-off antenna	PTFE antenna with drip-off function	26+80 GHz: important is antenna design
Low DC			Limit to DC>4		With advance dynamics	With advance dynamics			
Foam formation					With advance dynamics	With advance dynamics			Depends on foam type! Best: GWR
Fast level changes									Pulse faster reaction time
Turbulent surfaces									
Aggressive media	PTFE-plated rod antenna	Sealing related			O-ring related	PTFE-plated, flush mounted		PTFE-plated, flush mounted	
High pressure/high temperature		XT+HT versions			XT+HT versions	Up to 200°C		Up to 200°C	
Absorption in ammonia		Installation with stilling well					On request	On request	Best GWR

■ Ideally suited – preferred option

■ Acceptable performance in most applications

■ Not usually recommended – consult Endress+Hauser

■ Not suitable



## 2. Guided wave radar

Guided wave radar (GWR) level transmitters are the first choice for installation in bridges. They have a number of significant advantages both on new installations and as a direct replacement for displacers on existing plants where they offer reduced maintenance and increased reliability.

GWR is also frequently used mounted directly in vessels where it can present advantages and disadvantages when compared to radar. These instruments operate independently of changes in product density and have no moving parts.



[More information on FMP50 >>>](#)

[More information on FMP51 >>>](#)

[More information on FMP52 >>>](#)

[More information on FMP53 >>>](#)

[More information on FMP54 >>>](#)

[More information on FMP55 >>>](#)

Guided wave radar uses time delay reflectometry (TDR) to measure the distance to a change in wave impedance, for example a liquid surface. TDR has been used for many decades in the telecommunications industry to detect cable faults along long cable runs with the ability to pinpoint a cable fault to a few centimetres in cable runs extending for kilometres. In the past 20 years, continual improvement in GWR technology means that it has been adopted for process level measurement applications across a wide variety of industries.



## 2.1 Level measurement using guided wave radar

The principle of operation of GWR is that a pulse of microwave energy is emitted from a high frequency generator and guided along the outside of the probe (waveguide). Many waveguide types are available with the most common being single or dual rod types, wire rope types and coaxial versions where a central rod is located within a metallic tube. The emitted microwave pulse reaches a change in dielectric and part of the energy is reflected. The amount of energy reflected at the surface is proportional to the ratio of the relative dielectric constants of the gas and liquid. Air has a dielectric constant of approximately one and most hydrocarbon gases will also have a similar value. Water has a dielectric constant of 80 and will therefore give an extremely strong echo as most of the pulse energy is reflected. Hydrocarbons generally have a relative dielectric constant of two to three so less of the energy is reflected. The reflected pulses are transmitted along the waveguide to the electronics where a microprocessor analyses and identifies the reflection from the product surface.

The distance (D) to the product surface is proportional to the time of flight (t) of the impulse:

$$Distance = \frac{t \cdot c}{2}$$

Where:

t = time (in seconds)

c = the speed of the radar pulse in ms<sup>-1</sup>

For a low dielectric liquid only part of the energy is reflected at the surface this results in a smaller amplitude echo for evaluation as the level signal, but the energy that is not reflected can be put to further measuring use. The pulse continues through the liquid and travels at a reduced velocity dependent on the relative dielectric constant of the liquid. This will also create a reflection from the end of the waveguide. Due to the slower propagation speed through the liquid, the echo from the end of the waveguide will appear to move further away as the liquid level rises. The level can be calculated from this by the transmitter. This method can provide a useful back-up level measurement in case of disturbance resulting in a poor echo from the liquid surface.

In interface applications the pulse is reflected once more at the interface point to a second liquid with a higher dielectric constant. The distance to the interface layer can also now be determined taking into account the delayed Time-of-Flight of the pulse as it traverses the upper liquid on its outgoing and return journeys. For interface applications where an emulsion layer may be present, capacitance is preferred but has its own disadvantages. A solution is found in Endress+Hauser's FMP55 that uses both these technologies in unison.

To suit different applications there are a variety of main waveguide types used: rod, rope and coaxial. Other types such as twin rod also exist but are less common. As the name suggests the function

of the waveguide is to act as a path for the microwave pulse. As the energy does not disperse in the same way that it does for a free space radar, long measuring ranges and low dielectric liquids can be measured.



### Rod waveguides

- A plain metallic rod that can either be inserted directly into a vessel, stilling well or bypass chamber.
- For highly corrosive products this can be supplied coated.
- For long lengths or to allow installation with limited headroom uncoated waveguides are available as sectional pieces to be screwed together during installation.
- Not suitable for agitated vessels in general due to the lateral load experienced by the waveguide.

When used in a stilling well or bypass chamber, it is advisable to use a spacer or centring disc at the waveguide end to ensure that space is maintained around the waveguide.

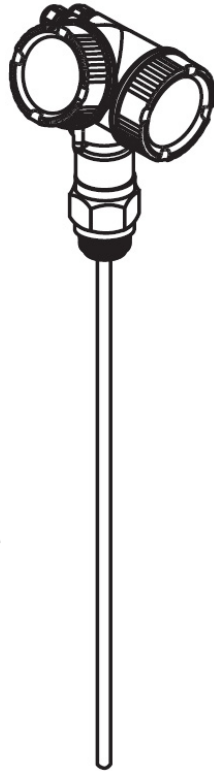

### Rope waveguides

- Uses a wire rope in place of the solid wave guide which is either weighted or attached to the bottom of the vessel so that it remains vertical. For highly corrosive products this can be supplied coated.
- Ideal for long lengths or to allow installation where there is limited headroom.
- Uncoated waveguides can easily be shortened to the correct length during installation.
- Not suitable with agitation unless the end of the waveguide is fixed to the vessel bottom.

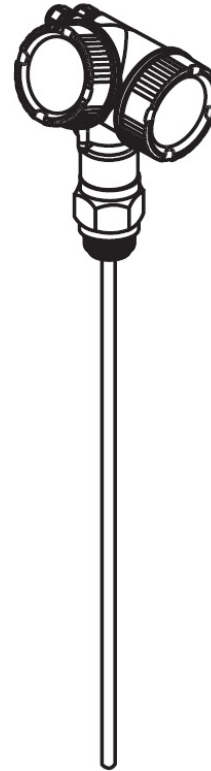

### Coaxial waveguides

- A coaxial waveguide consists of a solid metallic waveguide but this runs concentrically down the inside of a metallic tube. The outer tube is perforated to allow liquids to easily flow to the inside.

This arrangement offers some major advantages:

- The microwave pulse is concentrated into the space between the waveguide and coaxial tube. This allows lower dielectric liquids such as liquefied gases to be measured as the return echo is increased.
- Nothing outside of the coaxial tube can create an echo that might interfere with the detection of the level echo. This makes them ideal for installation in plastic tanks.
- The mechanical load that the waveguide can resist is greatly increased making them suitable for agitated vessels.

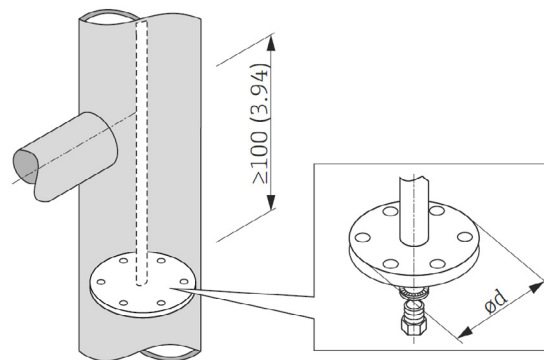
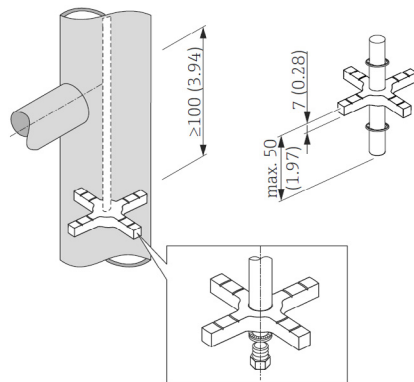
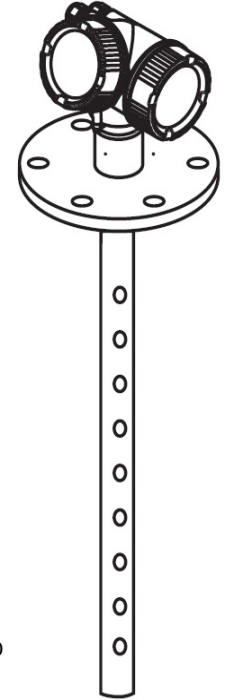

Metallic centring disc preferred for level applications, plastic for interface applications. Should be mounted at least 100mm below the minimum measuring range.

 [Find out more about our Levelflex FMP55 >>>](#)

## 2.2 Levelflex gas phase compensation

Automatic gas phase compensation works by deliberately creating an echo at a known distance. The apparent shift in this reference echo is then used to calculate a correction factor that is applied to the measured distance.

**Gas phase compensation** The distance calculation assumes a constant known propagation speed for the microwave pulse. The microwave propagation speed varies with the square root of the dielectric of the gas above the liquid. Typically at conditions near atmospheric all gases have a dielectric constant close to 1 so there is little or no appreciable effect on accuracy. At high pressures especially with polar gases such as steam the effect is pronounced.

The absolute error increases in direct proportion to the distance from the mounting flange to the liquid surface to be measured, such that a doubling of this distance will result in a doubling of the error. Taking this into account, it is apparent that such measuring errors could have critical safety implications for low level alarms and an automatic correction method should be considered.

 [Watch our video on gas phase compensation >>>](#)

### Coax probes

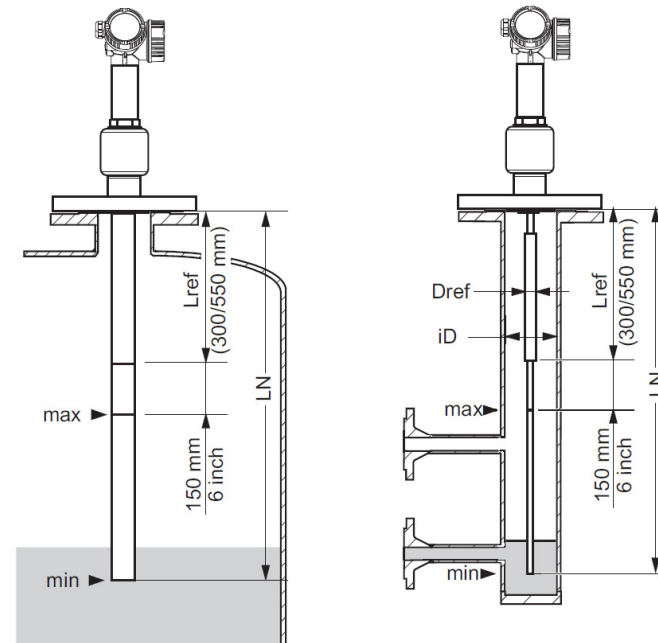

Coax probes with reference reflection can be installed in any tank (free in the tank or into a bypass). Rod probes should be installed in a bypass or stilling well.

## 3. Capacitive level measurement

Capacitive level measurement offers a wide variety of possibilities for level measurement in liquids.

This is one of the earlier methods used for the electronic measurement of liquid levels and so is well known and still widely used today. One of the prime advantages of capacitive level measurement is the extremely fast response time, making it suitable for very fast changing levels where radar and guided wave radar may struggle. They are also ideal for interface applications.

The space between two unevenly charged objects is called an electric field. In this space, one electric charge exerts a force on another charge. If an alternating voltage is applied to a parallel-plate capacitor, current starts flowing. The strength of the current depends on the dielectric material between the plates, for example air or a medium. The dielectric material increases the capacity of the capacitor and, thus, the current flow.

The principle of capacitive level measurement depends on capacity changes. This method takes advantage of the fact that products in tanks have a different dielectric constant than air or gases. To measure levels a probe inside of the tank and the electrically conducting tank wall form a capacitor. As the rising level covers the probe, the measured capacitance changes and the level is measured. As the level falls, the probe reports a reduction in capacitance and hence a reduction in level.

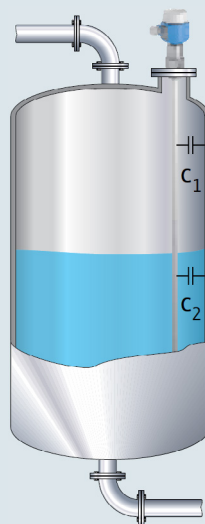

### Capacitance

The principle of capacitive level measurement is based on the capacitance change. The probe and the tank wall form a capacitor where the capacitance is dependent on the amount of product in the tank: an empty tank has a lower capacitance, whilst a filled tank a higher capacitance.



[Watch our video on capacitance technology >>>](#)



### Liquicap

Exact measurement from the end of the probe to the process connection without any blocking distance. Very fast response times. Unaffected by density, turbulence and vapor pressure.

- Process temperatures up to 200°C
- Process pressures up to 100bar



[Find out more about capacitance technology >>>](#)

For a conductive liquid capacitance  $c_2$  is shorted so it is essential that a fully insulated probe is used. In this case we are then measuring the capacitance across the non-conductive PTFE probe lining that will vary with the change of level.

For conductive liquids with conductivity in excess of  $100\mu\text{Scm}^{-1}$  this means that the calibration is independent of changes in the liquid dielectric constant as the dielectric constant of the probe insulation remains constant and also independent of changes to the conductivity. Because of this a capacitance device can leave the factory calibrated ready for immediate use on a conductive liquid.

For conductivities below  $1\mu\text{Scm}^{-1}$  the accuracy is affected by any changes to the dielectric constant. Because of this capacitance level measurement is only suitable for non-conductive liquids where the composition is kept constant.

Between these two conductivities is a range where capacitance measurement is not advisable as the measurement becomes dependant on both the conductivity and the dielectric constant and capacitance based level measurement is not recommended. A more suitable technology should be chosen.

Traditionally capacitance measurement has a reputation for needing fairly regular recalibration. In the early days this was often due to drift in the electronics. However with more modern devices this has been eliminated. Another major source of measurement error can be build-up and this is discussed on page 16.

## Operating range of Liquicap

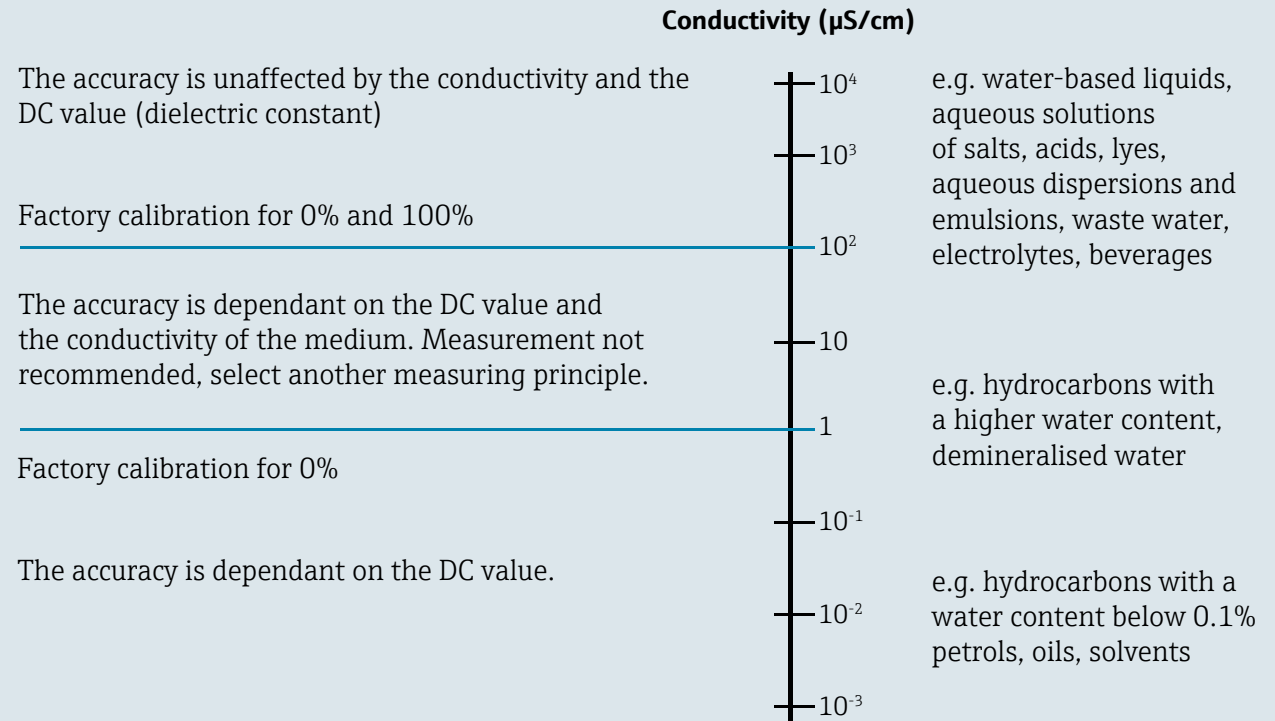

**Interface measurement** Capacitance is ideal for the measurement of the interface level of two liquids often found in separation processes in the oil & gas industry. The advantage in these applications over guided wave radar comes when there is an emulsion layer present between the two liquids. It is possible that there is no distinct change from one liquid to another and so there is no abrupt change in impedance to give the echo required by the guided wave radar. A capacitance transmitter will give no information about the thickness of the emulsion layer but instead will give an averaged value so that the interface will be reported as somewhere within the emulsion layer. Changes in the conductivity of the upper oil level and build-up may have an effect on the accuracy necessitating recalibration. The unique Endress+Hauser FMP55 eliminates this problem by combining capacitance and guided wave radar in a single device allowing the capacitance values to be automatically compensated.

 [Find out more about the Levelflex FMP55 for interface measurement >>>](#)

**Rod probes** This is the most common form of capacitance probe used for level measurement. A probe coated in non-conductive PFA is used. This can be of a variety of thicknesses to cope with various lateral loads that may be experienced. Mounting can be directly into a vessel or they can be fitted into bypass chambers or stilling wells. The probe may incorporate an inactive section at the upper end that does not take part in the measurement. In the inactive length, an outer grounded screen shields the active part from seeing any changes in capacitance.

**Rope probes** Similar in design to the rod probe but made using a PFA-coated wire rope with a weight at the bottom which is also coated. These are ideal for long measuring ranges or where headroom above the vessel prevents installation of a rigid rod. These may also have a rigid inactive section.

**Coaxial (ground tube)** To maximise the change in capacitance (and hence the accuracy) when measuring liquids with low dielectric constants a concentric ground tube may be used to decrease the distance across which the capacitance is measured since the distance between the two plates of a capacitor is an inverse function of capacitance. Another application is when measuring non-conductive liquids where the distance to the tank wall is non-uniform, without a ground tube the change in capacitance would be non-linear and hence the measured level would be incorrect. Mounting a rod probe in a stilling well or a bypass chamber has the same effect. Ground tubes should not be used if build-up is possible.

As the total capacitance measured by the entire active part of the probe is measured, it is possible to install a capacitance transmitter for level or interface measurement from the bottom of a vessel. This can prove very useful on the lower part of a vertical split compartment vessel or measuring a small interface range at the bottom of a large vessel.

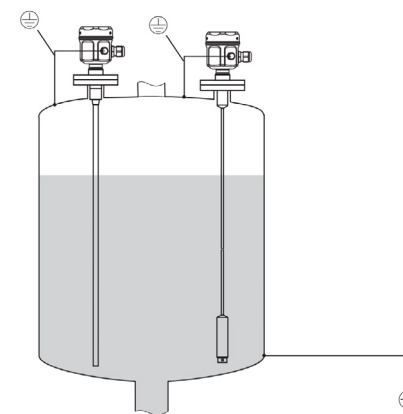

Rod and rope capacitance transmitters must be fitted in a metallic vessel with a good electrical connection between transmitter and vessel.

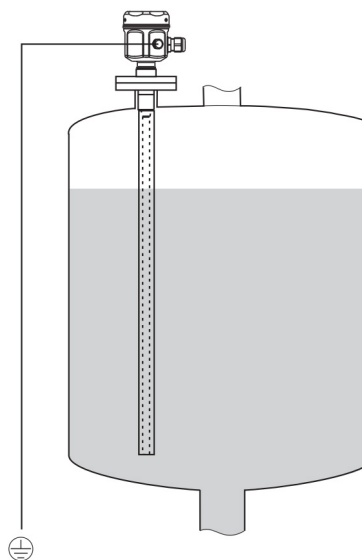

With a ground tube the transmitter can be installed in a vessel of any material.

### Installation instructions capacitance

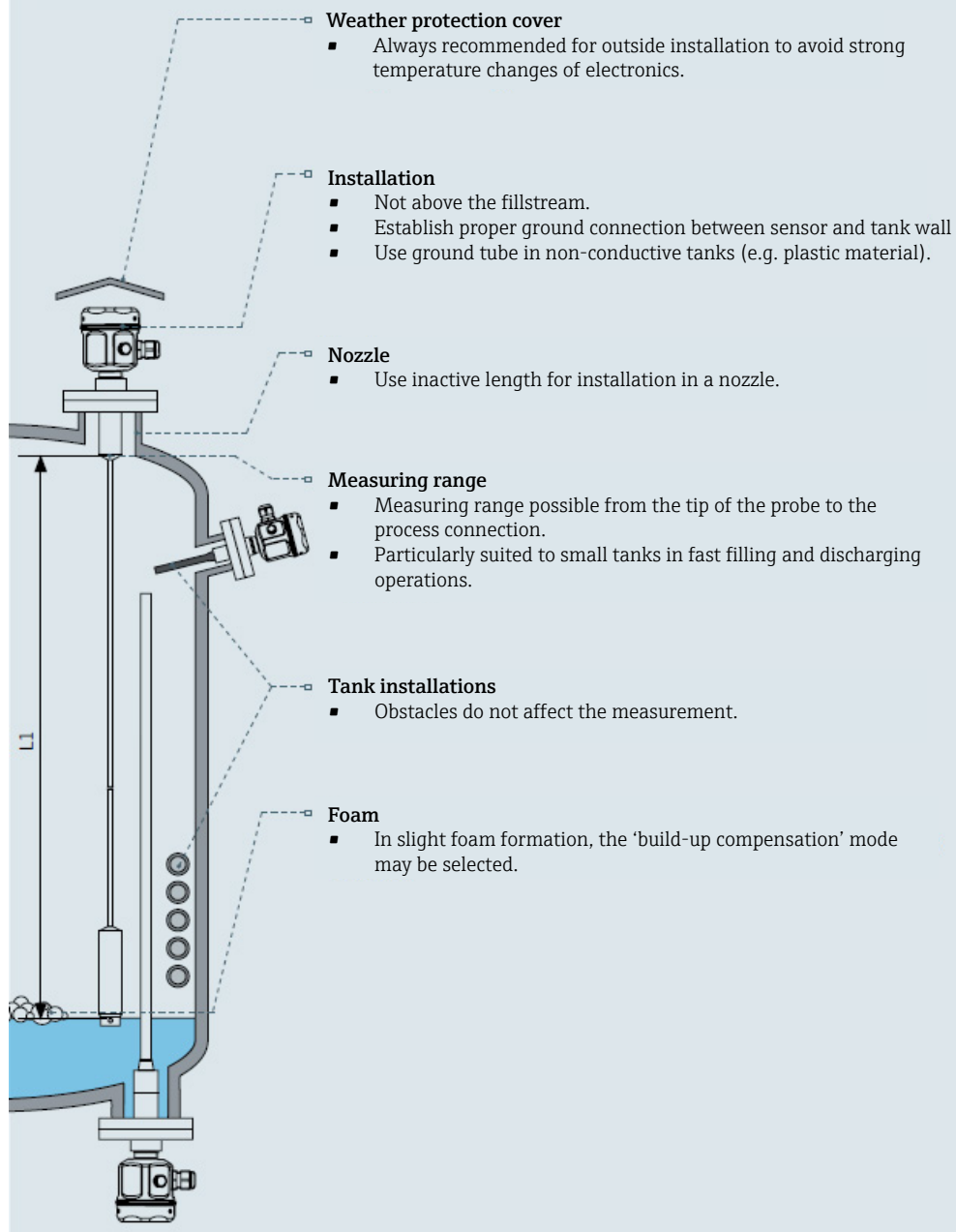

Build-up on the surface of the probe can have a considerable effect on the measurement accuracy. To examine the effect whether the build-up and the liquid being measured is conductive must be taken into account.

**Non-conductive liquid** In non-conductive liquids the measured value depends on the dielectric constant of the liquid and a thin conductive or non-conductive build-up does not, or only in a minor way, influence the measured result. For heavy build-up the effect on the measurement accuracy is dependent on the distance from the probe to the vessel wall. As a ground tube would normally be used for a non-conductive liquid, capacitance is not recommended for heavy build-ups as the distance will be small relative to the build-up thickness.

**Conductive liquids** Applications with even an extremely thin conductive build-up were traditionally not regarded as suitable for capacitance level measurement as the effect on accuracy was too great. The conductive build-up on the probe rod acts like an additional probe insulation capacitance and a build-up resistance. This additional insulation capacitance and resistance through the build-up cause an additional current, which – for the standard operating mode – results in a measuring error.

Extensive measurements and simulations have shown that the apparent current through the build-up has a phase shift of  $45^\circ$ . Considering this, the build-up can be compensated in capacitance level transmitters with build-up compensation when the phase of the current is also measured.

For a non-conductive build-up when measuring a conductive liquid the effect is to increase the separation of the two halves of the capacitor formed and so a considerable measurement error is introduced with thicker build-up necessitating cleaning or frequent recalibration.



## 4. Hydrostatic

Hydrostatic level measurement is one of the oldest technologies used in continuous level measurement with pneumatic systems predating the current wide variety of electronic systems.

A liquid column above a point exerts a force (pressure) proportional to the height of the liquid column above the point and the density of the liquid.

$$P = \rho \cdot g \cdot h$$

Where:

$h$	=	Liquid height
$P$	=	Hydrostatic pressure
$\rho$	=	Liquid density
$g$	=	Acceleration due to gravity

For a known constant liquid density the transmitter can calculate the liquid level as a function of the pressure as  $g$  and  $\rho$  are constants.

$$h = \frac{P}{\rho \cdot g}$$

Hydrostatic level measurement can be split into two main fields, gauge pressure measurement and differential pressure measurement. In an open-vented vessel where the gas space above the liquid is at atmospheric pressure, a gauge pressure transmitter can be used.



## Pressure vs differential pressure - what are the differences?

### Hydrostatic (pressure)



Hydrostatic level measurement in open (vented) tanks is based on the determination of the hydrostatic pressure which is generated by the height of the liquid column. The obtained pressure is this a direct measure for the level.

#### Cerabar and Deltapilot

- Unaffected by dielectric constant, foam, turbulence and obstacles.
- Condensate-proof, watertight and long-term stable CONTITE™ measuring cell with optimised temperature shock behaviour (Deltapilot S).
- Process temperatures up to 752°C.

VS

### Hydrostatic (differential pressure)

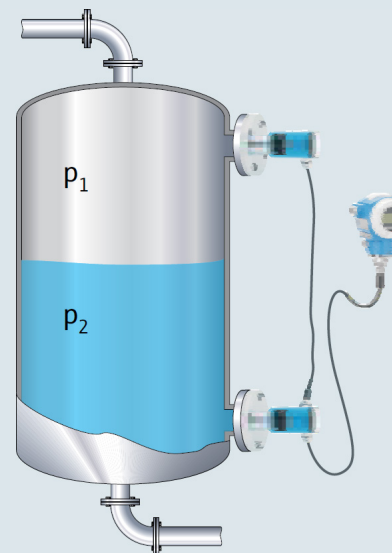

In closed, pressurised tanks, the hydrostatic pressure of the liquid column causes a difference in pressure. The same leads to a deflection of the measuring element which is proportional to the hydrostatic pressure.

#### Deltabar

- Unaffected by dielectric constant, foam, turbulence and obstacles.
- High overload resistance.
- Process temperatures up to 400°C.
- Process pressures up to 420bar.
- Unaffected by ambient temperatures (Deltabar electronic DP).

For a closed vessel with a gas pressure different to atmospheric this pressure must also be taken into account and typically a differential pressure (DP) transmitter is used. The hydrostatic pressure in the calculation on page 17 then becomes the differential pressure between the pressure at a point in the liquid and the gas space above ( $P = P_2 - P_1$ ).

Differential pressure may also be used for interface measurement provided the densities of both upper and lower liquids are constant.

Like every measurement level technique, hydrostatic pressure measurement has advantages over other technologies in some circumstances and disadvantages in others. It is not affected by the same physical properties that affect radar, microwave and capacitance transmitters such as dielectric constant and conductivity. Foam is a particular problem for many other technologies that has only the smallest influence on accuracy for a hydrostatic level measurement if the foam is of low density when compared to the liquid density. Hydrostatic measurement is not affected by internal vessel fittings or the shape of the vessel and this allows use even where there is no direct path through the vessel due to internal baffles or packing.

Hydrostatic measurement is instead greatly affected by changes to the liquid density, which the other principles discussed are immune to. This limits the application to liquids that remain at a constant density. Mixing and reaction vessel applications are generally not suitable. It is possible to have a system to measure the liquid density such as a DP measurement across a fixed height

that is covered by the liquid. This measured density can then be used to correct changes in liquid density in the control system. However, unless other application constraints mean that another measurement technology is not suitable, this method should be avoided due to the increase in cost, measurement error and complexity. Build-up on the pressure sensing face is acceptable provided it is non-hardening.

Correct installation of transmitters for hydrostatic level measurement is essential for both gauge measurement and DP types.

### Deltabar PMD75 DP transmitter



 [Find out more about the Deltabar PMD75 DP transmitter >>>](#)

### Deltabar FMD78 DP transmitter



 [Find out more about the Deltabar FMD78 DP transmitter >>>](#)

### Deltabar PMD55 DP transmitter



 [Find out more about the Deltabar PMD55 DP transmitter >>>](#)

### Gauge measurement

1. Always install the device below the lowest measuring point.
2. Do not install the device at the following positions where pressure influences may be present:
  - In the filling curtain.
  - In the tank outflow.
  - On the suction area of a pump.
  - At a point in the tank that can be affected by pressure pulses from the agitator.
3. Build-up on the sensor face will only have a limited effect on the accuracy provided it does not solidify

**Hydrostatic DP measurement** The same restrictions above apply for the lower sensor of a DP arrangement used for level measurement and for both sensors when used for interface measurement. Further installation considerations that can greatly affect the accuracy must also be considered. These are specific to how the vessel pressure is transmitted to the sensor.

**Diaphragm seals** Issues mainly relate to uneven thermal expansion and the following recommendations should be followed:

1. Level measurement accuracy is only guaranteed between the upper edge of the lower and the lower edge of the upper diaphragm seal.
2. In vacuum applications, it is recommended to install the pressure transmitter below the lower diaphragm seal. This will avoid a vacuum load

of the diaphragm seal caused by the presence of filling oil in the capillaries.

3. In order to avoid additional pressure fluctuations the capillaries should be free of vibration.
4. The capillaries should not be installed in the vicinity of heating or cooling pipes.
5. It is recommended to insulate the capillaries in a colder or warmer environment.
6. The ambient temperature and the length of both capillaries should be identical.
7. Two identical diaphragm seals (e.g. diameter, material, etc.) should always be used for the minus and plus side.

**Pressure pipe** Where a pipe is used to directly connect the differential pressure sensor to the vessel, issues generally relate to maintaining the same fluid (or absence of) in the interconnecting pipework to ensure there is no shift in the static hydrostatic pressure caused by changes to the fluid in the pipework.

1. Always connect the minus side above the maximum level.
2. Always install the sensor below the lower measuring connection so that the lower pressure piping is always filled with liquid.
3. Installation of separators and drain down valves to collect deposits in the HP piping and allow the flushing of contaminated liquids.

4. Calibrate at operating temperature.
5. A filled condensate vessel to provide constant pressure on the LP pressure line.

**Electronic DP** Electronic DP hydrostatic level measurement works by using two absolute pressure sensors mounted directly onto the vessel tapping points. They are connected using digital communications to remove errors caused by additional analogue to digital and digital to analogue conversions. The absence of either pressure piping or capillaries means that the additional constraints needed for traditional DP measurements no longer apply and only the mounting position issues discussed for a gauge hydrostatic transmitter need to be considered.

### Deltabar FMD72 electronic DP



 [Find out more about the Deltabar FMD72 electronic DP >>>](#)

## 5. General selection aid

It should be clear that knowledge of the process conditions and the installation properties are of vital importance to allow the selection of a suitable level transmitter.

The table outlines some of the main considerations for the four main technologies discussed here. The table is by no means exhaustive but having some knowledge of the way each measurement technology interacts with the process as given in the previous sections can be of great assistance when trying to decide the best-fit technology.

The following table compares the individual measuring methods and is designed to assist in a initial selection

Selection guide	Radar	Guided radar	Hydrostatic (pressure/dp)	Capacitance
Heavy condensation	Yellow	Green	Green	Green
Foam formation	Yellow	Green	Green	Yellow
Conductivity 1 $\mu$ S/cm	Green	Green	Green	Yellow
Changing media (density)	Green	Green	Red	Green
Low DC	Yellow	Yellow	Green	Yellow
Viscosity	Green	Yellow	Green	Yellow
Build-up formation	Green	Yellow	Yellow	Yellow
Small tank (blocking distance)	Yellow	Yellow	Green	Green
Hygienic application (cleanability)	Green	Green	Green	Green
Pressurisation	Green	Green	Green	Green
Simple maintenance (disassembly)	Green	Yellow	Yellow	Yellow
Independent of installation site	Yellow	Green	Yellow	Green
Unaffected by obstacles	Yellow	Green	Green	Green
Small tank (fast level change)	Yellow	Yellow	Green	Green
CIP/SIP temperature cycles	Green	Green	Green	Green

■ Recommended   
 ■ Restricted (observe limits)   
 ■ Not recommended

# Contact us

Endress+Hauser 

[www.uk.endress.com](http://www.uk.endress.com)

Endress+Hauser Ltd  
Floats Road  
Manchester  
M23 9NF  
0161 286 5000